

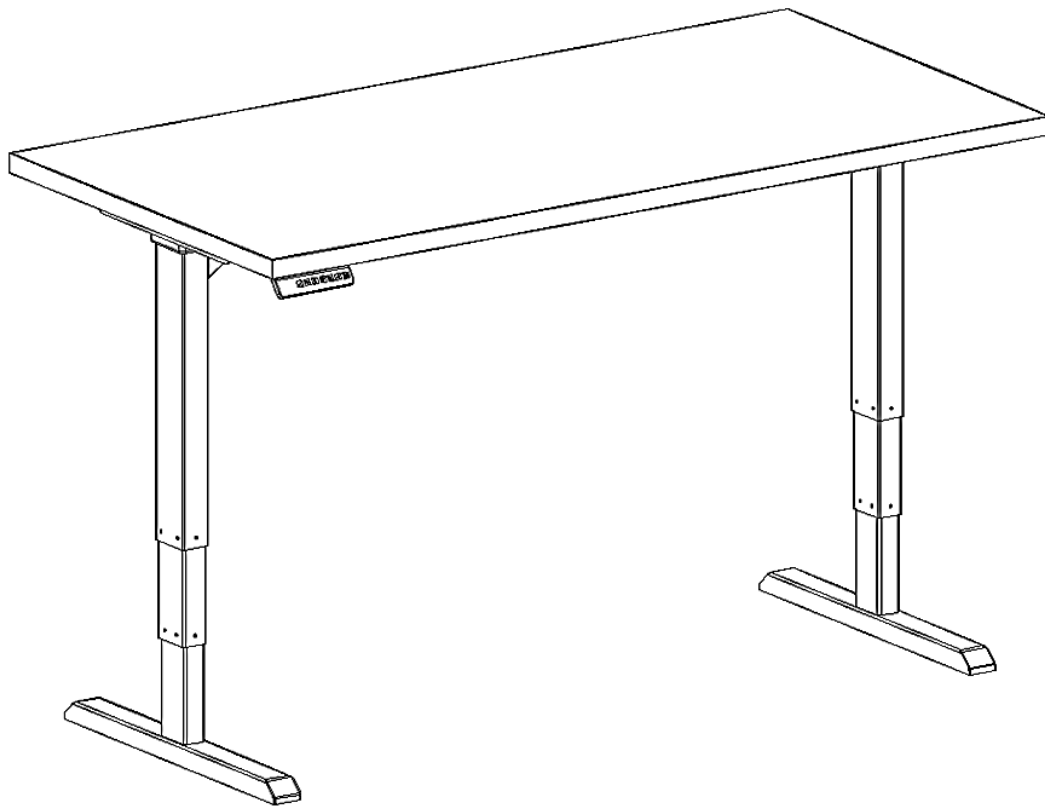

UP tables & worksurfaces (2-leg)



Installation and User Instructions

Step 1: INSTALL FEET AND MOUNTING BRACKETS TO LIFTING COLUMNS

- Use the provided machine screws.
- Fasten the machine screws by hand and tighten using an allen wrench.

NOTE: Both sides of the mounting brackets do not have the same size holes. The side with larger holes mounts to the lifting columns using the machine screws. The side with smaller holes mounts to the UP- table using wood screws. The machine screws do not fit through the smaller holes.

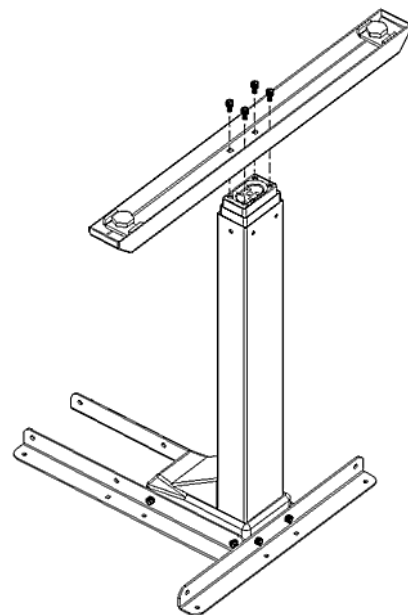
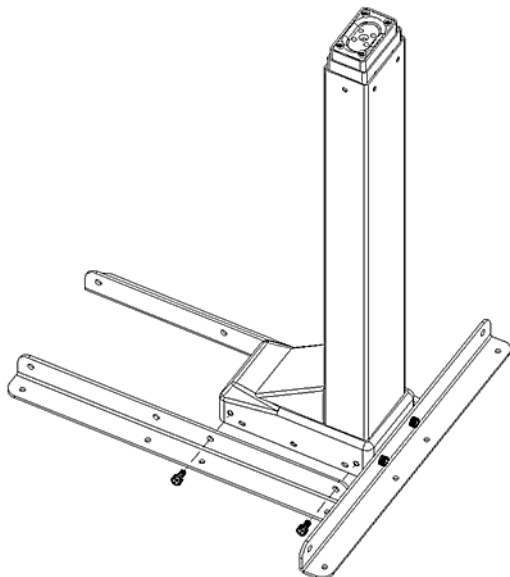
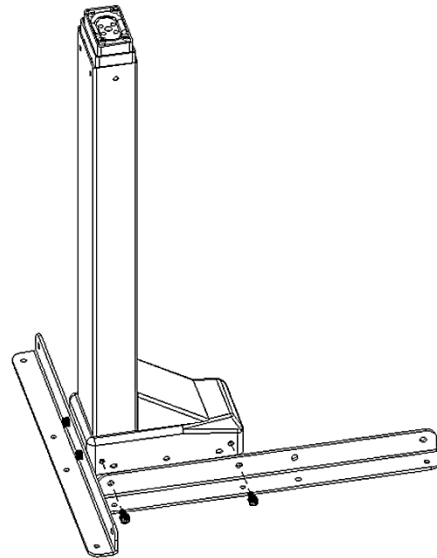
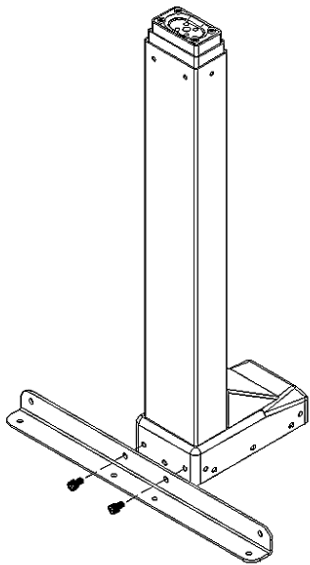

Step 2: INSTALL LIFTING COLUMN BASE ASSEMBLY TO THE UP-TABLE

- Use the provided wood screws.
- For UP-tables 60" and smaller – lifting column bases can be mounted at the table's edge or with slight overhang.
- For UP-tables larger than 60" – position lifting column bases 60" apart and mount with the same overhang on both sides (centered).

Step 3: MOUNT CONTROL BOX AND HANDSET TO THE UP-TABLE

- Use the provided wood screws.
- The Control Box can be mounted anywhere on the underside of the UP-table. Mounting the control box tucked behind the left or right lifting column is most ideal.
- The handset can be mounted anywhere on the underside of the UP-table's front edge.

Step 4: CONNECT CABLES

- Connect lifting column bases and handset to the control box using the provided cables as per the following diagrams. Adhesive backed cable clips can be used to secure the cables and prevent sagging. Once clips are positioned, then secure with wood screws.

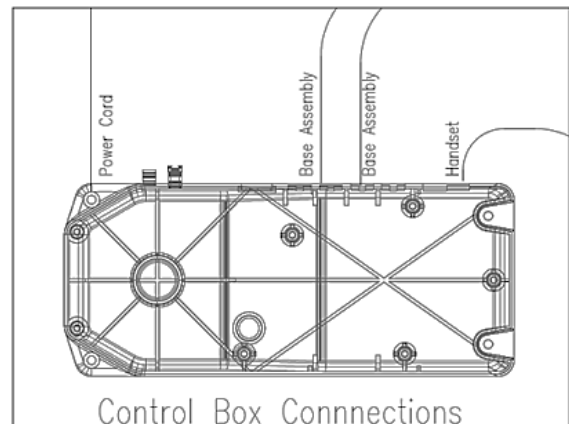
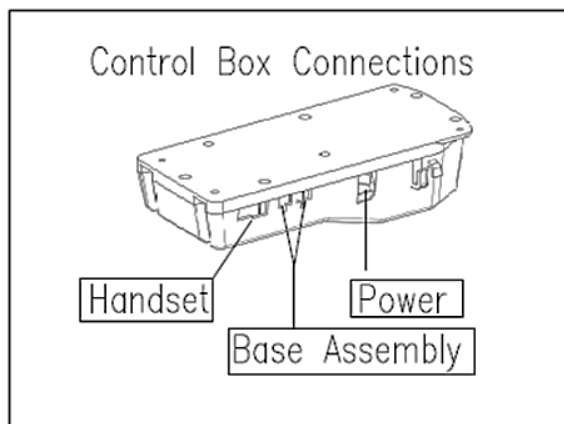
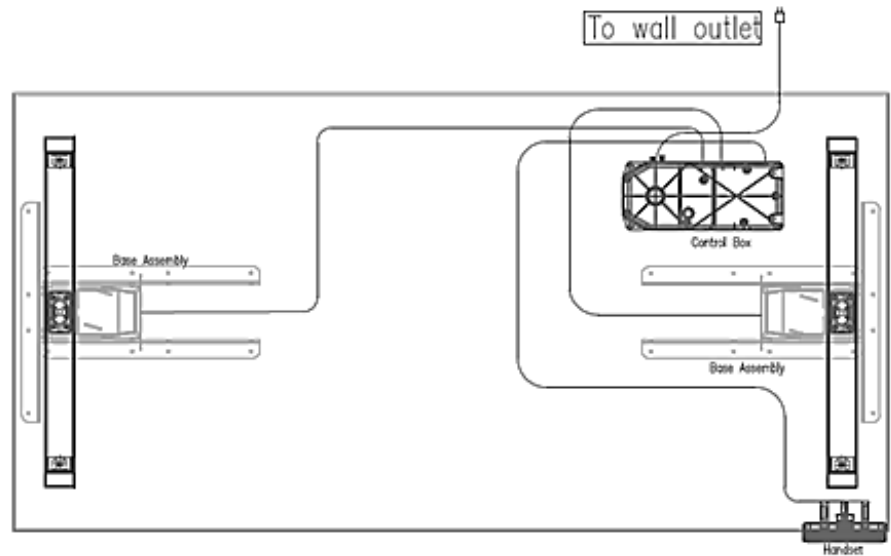
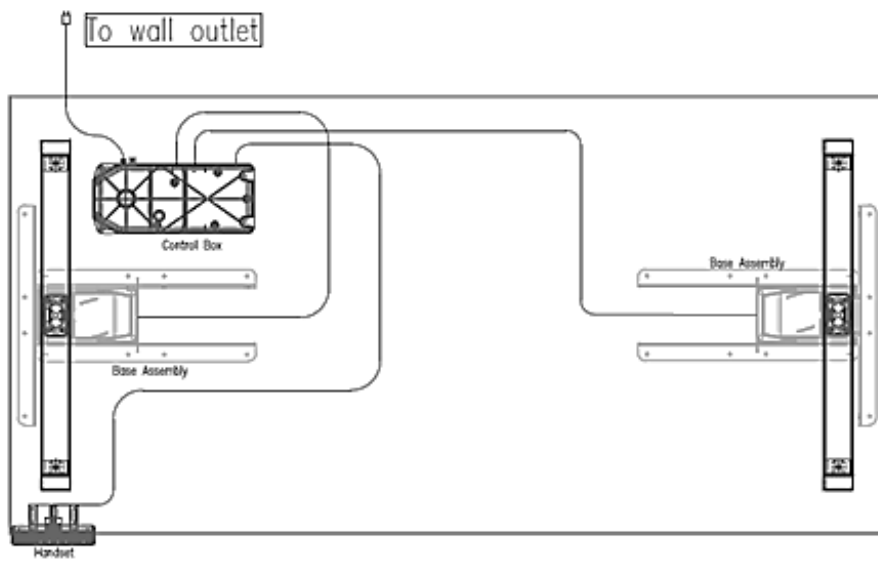



Step 5: TURN THE ASSEMBLED UP-TABLE RIGHT-SIDE UP

- Use two people and proper lifting techniques to prevent injury.
- Adjust the leveling glides on the feet as needed to ensure the UP-table is level.
- Plug the power cord into a 110V outlet.
- Make sure obstacles are not in the UP-table's path.
- Make sure cords have enough slack to accommodate the change of height.

Step 6: INITIALIZE UP-TABLE – RESET PRIOR TO USE

- Push and hold the DOWN button on the handset until the UP-table reaches it's lowest height. Release the DOWN button.
- Push and hold the DOWN button for approximately 5 seconds. Release the DOWN button. Continue doing this until the UP-table slightly rises and stops. When the UP-table slightly rises and stops the RESET procedure is complete.
- To program the presets – use the UP/DOWN buttons to reach your desired height, then press M followed by the preset you want to save (1 – 4).

TECHNICAL SPECIFICATIONS

- Height Range: 24.4 – 49.6"
- Speed: 1.5"/second
- Weight Limit: 350 lbs.
- Duty Cycle: 10% maximum; 2-minutes ON/18-minutes OFF

TROUBLESHOOTING

- If the UP-table is not functioning properly it may need to be RESET. Follow the RESET procedure outlined in Step 6.
- If the handset displays an error code check that all connections are secure and perform the above RESET procedure.
- If the handset displays HOT, let the UP-table cool down for 20 minutes.
- If the UP-table is not level adjust the leveling glides on the feet.

NOTE: The UP- table might need RESET if ever unplugged or if any connections are disconnected.



****SAFETY AND WARNINGS****

- Inappropriate use of this product may cause property or bodily injury.
- Not intended for use by children or persons who require supervision.
- Make sure obstacles are not in the UP-table's path and all cords are of appropriate length.
- Do not open any of the UP-table's components – Risk of electric shock.
- Risk of Pinch Point – the UP-table should have a minimum of a 1" gap around all sides.
- Do not sit, stand, or crawl on or under the UP-table.
- Keep all electrical components away from liquids.

LIABILITY: The manufacturer does not accept warranty/liability claims for damages caused by improper use.



OFFICE FURNITURE®

Manufactured by National Office

**15655 Brookpark Road
Cleveland, Ohio 44142**